

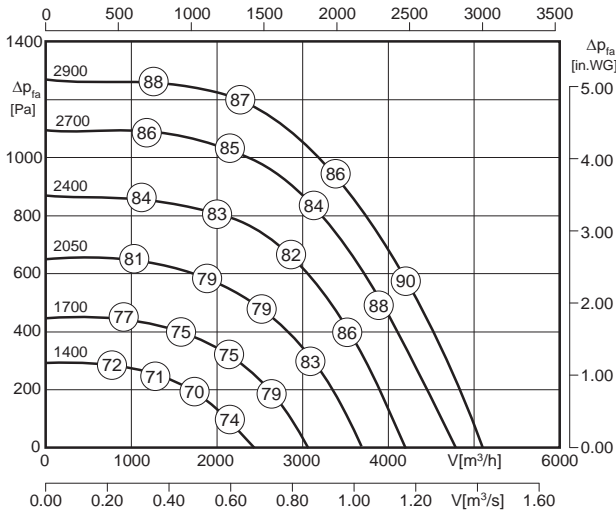

- schnelle Inbetriebnahme
- integrierte Regelung (EC-Controller)
- rückwärtsgekr. Hochleistungslauftrad
- einfache Einregelung und Anpassung an die Anlage
- Drehzahl stufenlos steuerbar
- unabhängig von der Netzfrequenz (50/60Hz) bei gleicher Leistung
- fast start-up
- integrated control system (EC controller)
- backward curved high efficiency impeller
- simple setting and adjusting of the complete system
- speed continuously controllable
- independent of the supply frequency (50/60Hz), while providing the same level of performance

**Technische Daten / Technical data:**



**Geräusche / Sound levels:**

$L_{W(A)5} = L_{W(A)8} - 7 \text{ dB}$   
 $L_{W(A)6} = L_{W(A)8} - 3 \text{ dB}$

*L<sub>W(A)8</sub> ist in der Luftleistungskennlinie dargestellt is displayed in air performance curve*

$L_{W(A)5\text{okt}} = L_{W(A)5} + L_{W(A)5\text{rel}}$   
 $L_{W(A)6\text{okt}} = L_{W(A)6} + L_{W(A)6\text{rel}}$   
 $L_{W(A)8\text{okt}} = L_{W(A)8} + L_{W(A)8\text{rel}}$

LWArel A-bewertet bei V=0,5*Vmax LWArel A-weighted at V=0,5*Vmax	fM [Hz]						
	125	250	500	1K	2K	4K	8K
LWA5 [dB(A)] Ansaugseite / inlet side	-23	-8	-5	-7	-8	-9	-15
LWA6 / LWA8 [dB(A)] Ausblasseite / outlet side	-28	-9	-6	-5	-7	-10	-21

Düsenbeiwert / Calibration factor :  $k_{10} = 75$

Ventilatortyp / Fan Type	U [V]	f [Hz]	P [kW]	I <sub>N</sub> [A]	n [min <sup>-1</sup> ]	t <sub>r</sub> [°F]	t <sub>r</sub> [°C]	⚠	★	⚖ [kg] GKHR	⚖ [kg] GKHM	⚖ [kg] GKHS
<b>GKH_315-CIB.100.5FA IE</b>	3 ~ 380-480	50 / 60	1.6	2.6 <sup>1)</sup>	2900	104	40 / 60*	IP54	01.390 a)	10.5	18.5	18.5

<sup>1)</sup> 60°C nur mit Drehzahlreduzierung auf 2400 min<sup>-1</sup> (8,0V) möglich / 60°C only possible with speed reduction to 2400 min<sup>-1</sup> (8,0V)  
<sup>1)</sup> bei 400V (50Hz) / at 400V (50Hz)  
 60Hz-Daten siehe Tabelle Seite 58 / 60Hz data please see table on page 58

**Schaltbild / Wiring diagram:**

01.390

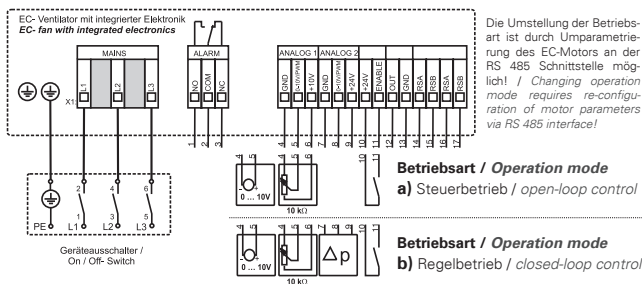

**Maße / Dimensions : [mm]**

GKHS

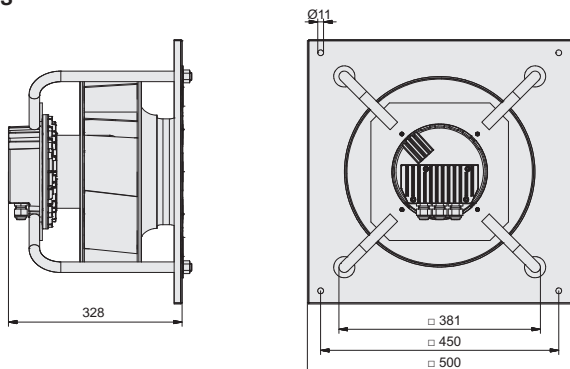

GKHR

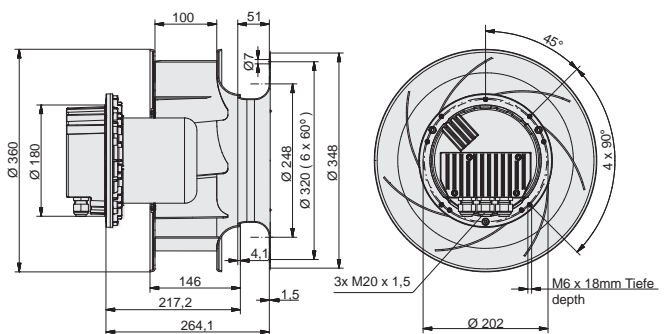

GKHM

